



**HERVISA
PERLES**



ES A08 904 617

C/Guifre el Pilos 1 bis
08213 - Polinya (Spain)

TYPES / MODELS

E-POWER 1M

E-POWER 2M

230V 50/60Hz

- (E) Manual del Operador
- (GB) Operators Manual
- (F) Manuel De L'Opérateur
- (S) Bruksanvisning
- (PL) Instrukcja Obsługi
- (RUS) Руководство для оператора
- (LT) Naudojimo Instrukcija
- (RO) Manual de Utilizare
- (NO) Betjene Håndbok
- (CZ) Na'vod K Obzluze
- (D) Bedienungshandbuch
- (BG) Оператор Ръчен



EP1,2-19/01



* SEGURIDAD ELECTRICA * ELECTRICAL SAFETY * SECURITE ELECTRIQUE *
 ELEKTRISK SAKERHET * BEZPIECZENSTWO ELEKTRYCZNE *
 ЭЛЕКТРИЧЕСКАЯ БЕЗОПАСНОСТЬ * DARBO SU ELEKTRINIAIS *
 SIGURANTA ELECTRIC * ELEKTRISK SIKKERHET * ELEKTRICKYM NARADIM
 * ELEKTRISCHE SICHERHEIT * ЭЛЕКТРИЧЕСКА БЕЗОПАСНОСТ *

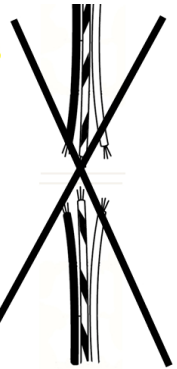
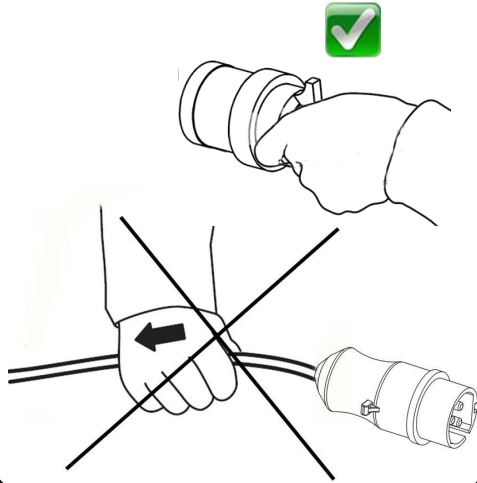
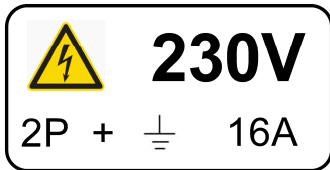
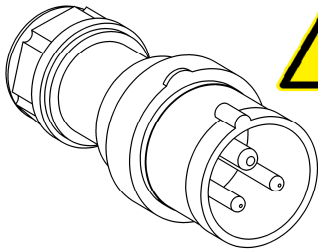

- *Precaución: Red con toma tierra
- *Warning: Grounding electrical network
- *Attention: Réseau électrique à la terre
- *Varning: Elnätet elektrisk jordning
- *Uwaga: Sieć elektryczna uziemienia
- *Внимание: сети электрического заземления
- *Atsargiai: Maitinimo elektros įžeminimo
- *Atenție: Rețea de împământare electrică
- *Advarsel: Stikkontakt grunnstøting
- *Upozornění: Napájecí elektrické uzemnění
- *Achtung: Netz elektrischen Erdung

*Внимание: електрическата мрежа електрически заземяване



PROTEGIDO * PROTECTED * PROTÉGÉ * SKYDDAD * OCHRONNY * ОХРАНЯЕМЫХ * SAUGOMA *
 * PROTEJATE * BESKYTTET * CHRÁNĚNÉ * GESCHÜTZT * ЗАЩИТЕНИ *



AUSENCIA TOMA TIERRA
 ABSENCE GROUNDING CONNECTION
 Mise à la terre L'ABSENCE
 FRÄNVARO JORDNING ANSLUTNING
 Uziemieniem BRAKU
 ОТСУТСТВИЕ заземления
 NEDARBINGUMAS dangai susijungian
 Absenta împământare connection
 FRAVÆR JORDING TILKOBLING
 ABSENCE uzemnění
 KEINE Erdung
 Липсата ЗАЗЕМЯВАНЕ ВРЪЗКА

TENSION E INTENSIDAD
 VOLTAGE AND CURRENT
 TENSION ET COURANT
 Spännings-och
 NAPIĘCIA I PRĄDU
 Напряжение и ток
 Įtampos ir srovės
 De tensiune și curent
 Spenning og strøm
 NAPĚTÍ A PROUDU
 SPANNUNG UND STROM
 Напрежението и тока

SOBRECALENTAMIENTO
 OVERHEATING
 SURCHAUFFE
 ÖVERHETTNING
 PRZEGRZANIA
 ПЕРЕГРЕВА
 Perkaitimas
 SUPRAÎNCĂLZIRE
 OVEROPPHETING
 PŘEHŘÁTÍ
 ÜBERHITZUNG
 ПРЕГРЯВАНЕ



* MEDIO AMBIENTE * ENVIRONMENT * ENVIRONNEMENT * MILJÖ *
 ŚRODOWISKO * ОКРУЖАЮЩЕЙ СРЕДЫ * APLINKA * MEDIU * MILJØ * ZIVOTNI
 PROSTREDI * UMWELTSCHUTZ * ОКОЛНАТА СРЕДА *

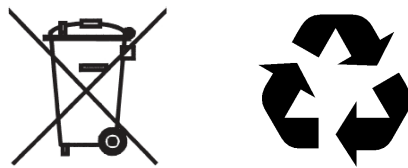

* SEGURIDAD GENERAL * GENERAL SAFETY * GENERALE DE SECURITE *
 * ALLMÄN SÄKERHET * BEZPIECZEŃSTWA * ОБЩАЯ БЕЗОПАСНОСТЬ
 * BENDROSIOS SAUGOS * SIGURANTA * GENERELL SIKKERHET * OBECNE
 BEZPECNOSTNI POKYNY * ALLGEMEINE SICHERHEIT * ОБЩИ БЕЗОПАСНОСТ *



* AREA DE TRABAJO * WORK AREA * ZONE DE TRAVAIL *
 ARBETSOMRADE * OBSZAR ROBOCZY * РАБОЧЕЕ МЕСТО * DARBO
 VIETA * ZONA DE LUCRU * ARBEIDSOMRADE * PRACOVISTE *
 ARBEITSUMFELD * РАБОТНОТО МЯСТО *



* QUICK VIEW *



* ALMACENAJE Y TRANSPORTE * STORAGE & TRANSPORTATION * STOKAGE & TRANSPORT * FÖRVARING & TRANSPORT * PRZECHOWYWANIE & TRANSPORT
 * ТРАНСПОРТ * LAIKYMAS & TRANSPORTAVIMAS * DEPOZITAREA & TRANSPORTAREA * LAGRING OG TRANSPORT * SKLADOVANI A PREPRAVA * LANGERUNG & TRANSPORT * СЪХРАНЕНИЕ И ТРАНСПОРТ *

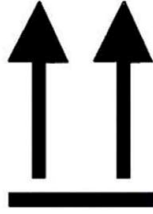

* GARANTIA * WARRANTY * GARANTIE * GARANTI * GWARANCJA * ГАРАНТИЯ
 * GARANTIJA * GARANTIA * GARANTI * ZARUKA * GARANTIE * ГАРАНЦІЯ *



WARRANTY



CONDICIONES DE GARANTIA EN RESTO DE PAISES CONSULTE CON SU DISTRIBUIDOR.
 WARRANTY TERMS OTHER COUNTRIES CHECK WITH YOUR LOCAL DEALER.

TERMES DE LA GARANTIE D'AUTRES PAYS VÉRIFIEZ AVEC VOTRE REVENDEUR LOCAL.
 GARANTIVILLKOREN ANDRA LÄNDER KONTROLLERA MED DIN LOKALA ATERFÖRSÄLJARE.

WARUNKI GWARANCJI INNYCH KRAJÓW SPRAWDŹ Z LOKALNYM SPRZEDAWCA.

УСЛОВИЯ ГАРАНТИИ ДРУГИЕ СТРАНЫ Проверьте с вашим местным дилером.

GARANTIJOS SĄLYGOS KITŲ ŠALIŲ PATIKRINTI SU SAVO VIETOS ATSTOVAS.

TERMENI DE GARANȚIE ALTE ȚĂRI Consultați-vă cu distribuitorul local.

GARANTIBETINGELSENE ANDRE LAND sjekk med din lokale forhandler.

ZÁRUČNÍ PODMÍNKY DALŠÍ ZEMĚ Poradte se s místními prodejci.

GARANTIEBEDINGUNGEN ANDERE LÄNDER PRÜFEN von Ihrem Händler.

Гаранционни условия ДРУГИ ДЪРЖАВИ Консултирайте се с вашия местен дилър.

WARRANTY COVERAGES



Mano de obra y piezas por defecto de fabricación

Labor and parts for manufacturing defects

Travail et de pièces pour des défauts de fabrication

Arbete och delar för tillverkningsfel

Pracy i części do wad fabrycznych

Труда и детали для производственных дефектов

Darbo ir dalys gamybos defektų

Forței de muncă și piese pentru defecte de fabricație

Arbeid og deler for produksjonsfeil

Práce a díů pro výrobní vady

Arbeitszeit und Teile für Fabrikationsfehler

Труда и части за фабрични дефекти

* SERVICIO Y MANTENIMIENTO * SERVICE AND MAINTENANCE * ENTRETIEN ET REVISION * SERVICE & UNDERHALL * SERWIS I KONSERWACJA * СЕРВИС И ОБСЛУЖИВАНИЕ * TECHNINE PRIEZIURA * SERVICE SI INTRETINERE
 * SERVICE OG VEDLIKEHOLD * SERVIS A UDRZBA * SERVICE AND WARTUNG
 * ОБСЛУЖВАНЕ И ПОДДЪРЖАНЕ *

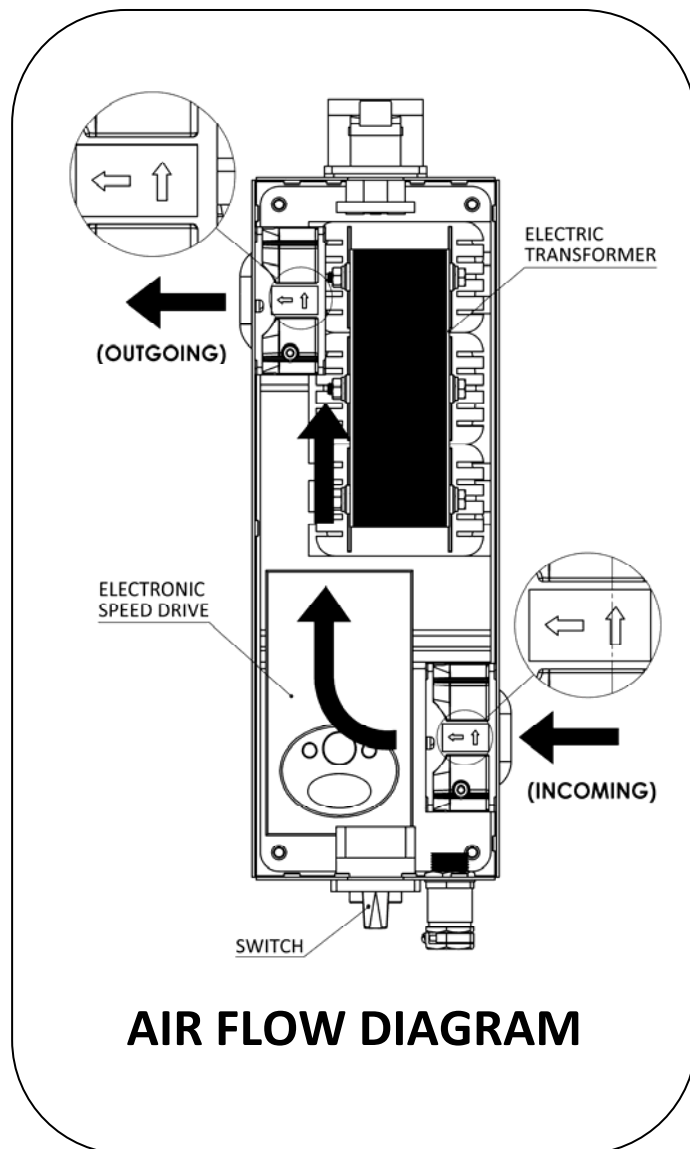
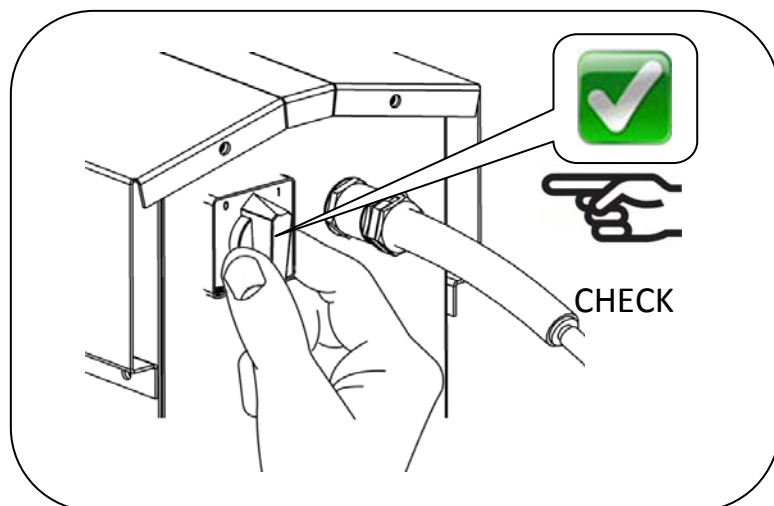
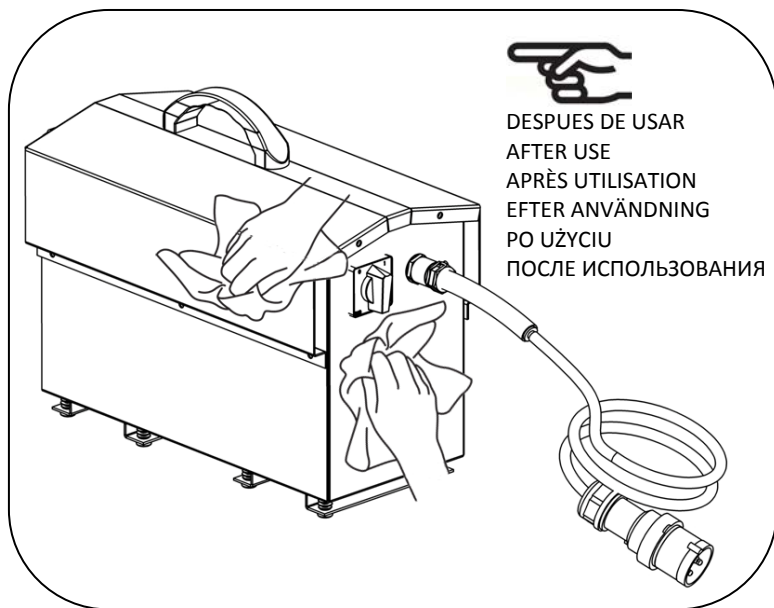
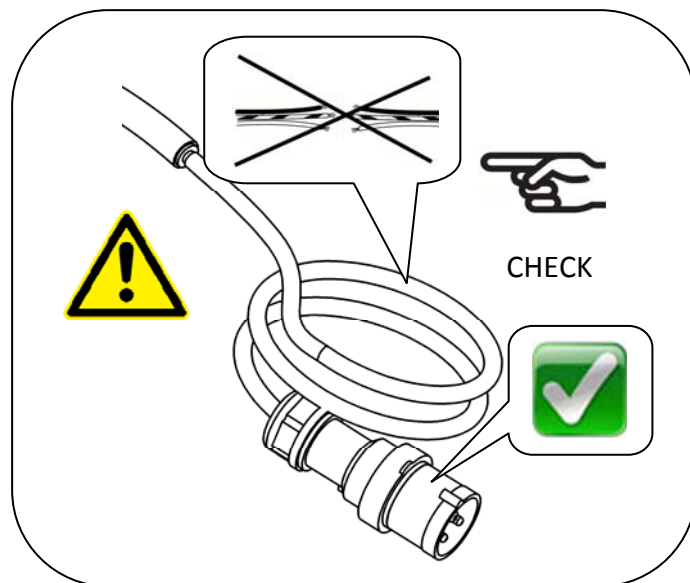
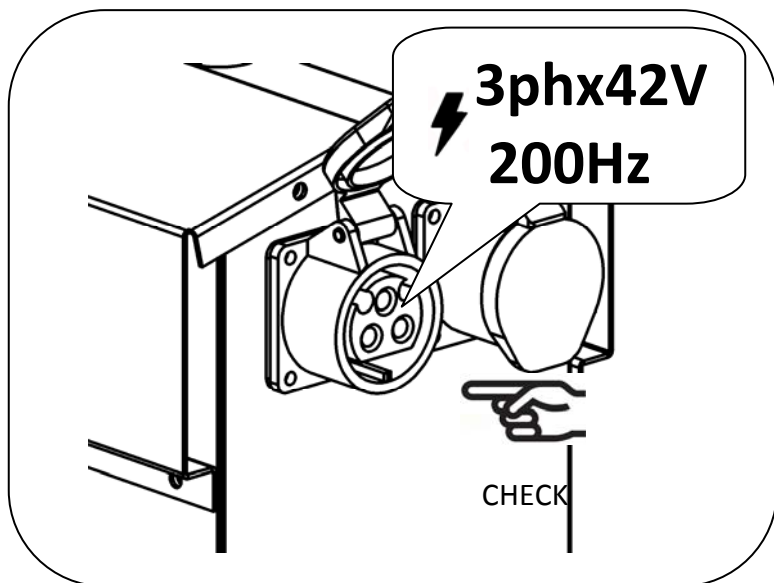

AIR FLOW DIAGRAM

* OPERATIVA * OPERATION * FONCTIONNEMENT * DRIFT
 * PRACA URZADZENIA * РАБОЧИЕ * NAUDOJIMAS * UTILIZAREA * BRUK
 * POKYNY PRO PROVOZ * HANDHABUNG * ОПЕРАТИВНА *

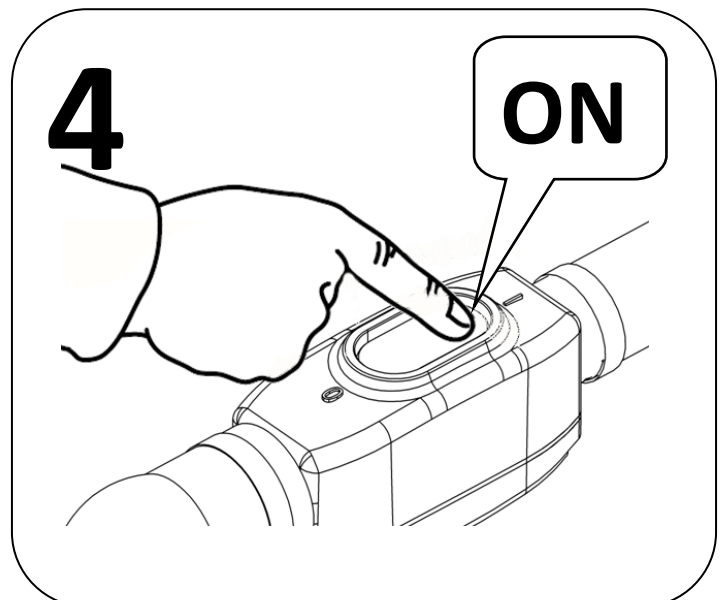
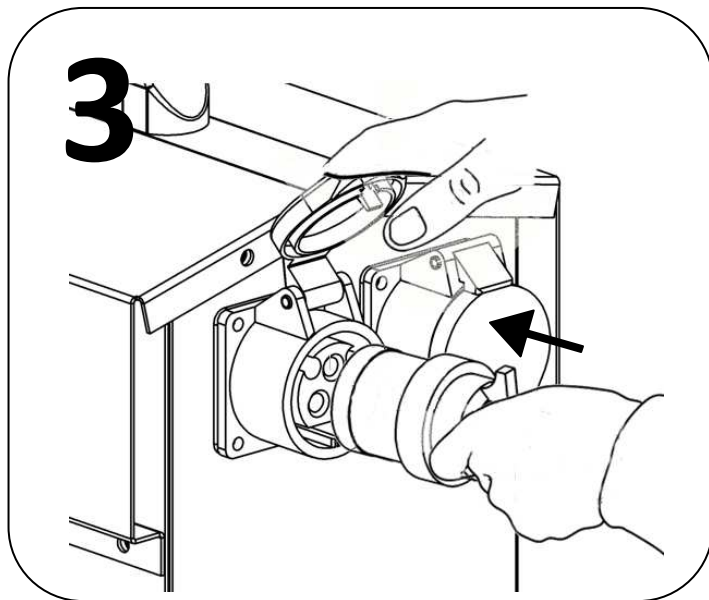
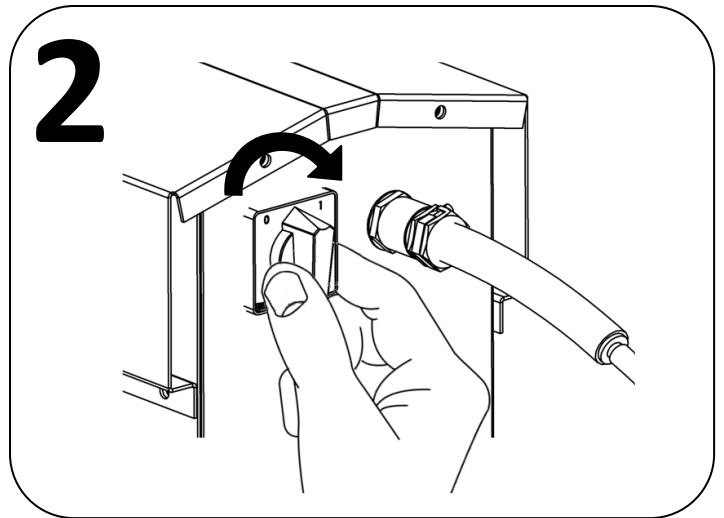
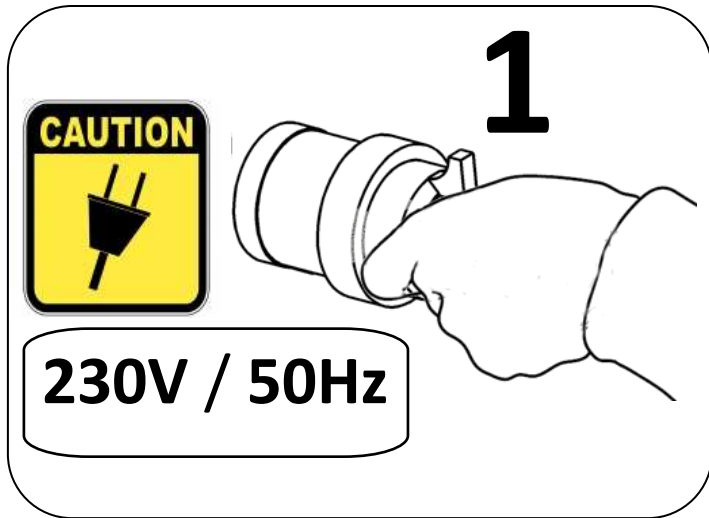

Hervis, s.a. ES A08 904 617

MADEN EU

E-POWER 2

CODE: EXP10172

2x42V/200Hz

SERIAL N°: 1111110172000270

DATE: 20/12/11

IP44

INPUT
230V / 50Hz - 22A / 1Ph
1,5 KW

OUTPUT
42V / 200Hz - 30A / 3Ph
2,4 Kw

CAUTION

POWER CONSUMPTION:
THE SUM OF CURRENT
(AMP) OF POKERS TO
CONNECT, CAN NOT BE
OVER OF THE CURRENT
(AMP) GENERATOR
VALUE DESCRIBED ON
THE DATA PLATE

OUTPUT
42V / 200Hz - 30A
2,4 Kw